



**HC-3**



**HC-2**



**HC-2W**

Edition : 1.0  
Date: (11/24)

## Instruction Manual

# INDUSTRIAL UNDER BENCH TOOLING CABINET HC-2, HC-3, HC-2W

Order Code: (A422, A423, A4225)

## BEFORE ASSEMBLING

Please read this instruction manual before assembly.



### CAUTION

Before assembly please pay attention to the following points in priority;

**Confirmation of components:** Before assembling, please confirm all parts arrived and are in good order.

**Site for assembly:** Please assemble it on the soft floor such as smooth carpet and flannel blanket. When you assemble on wooden floor, please put thin towels on the floor.

**Points for attention when assembling:** Please wear gloves to ensure that it can be assembled safely, and use two persons to help in the assembly process.

**Matters needing attention for operation:**

- Do not use for in proper use.
- Do not use it on inclined surface or uneven places.
- Do not use it when screw are loosened.

### TOOLS REQUIRED FOR ASSEMBLY

- M6 & M8 spanners
- Phillips Head Screwdriver

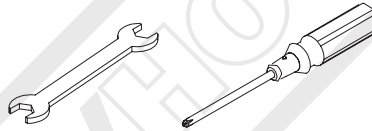

## PARTS LIST

### HC-2

Part No.	Description	Qty
1	Cabinet	1
2	Mounting Brackets	2
3	Fixing Tab	2
4	Screw - for boom	6
5	100mm Drawer	2
6	100mm Divider Set	2

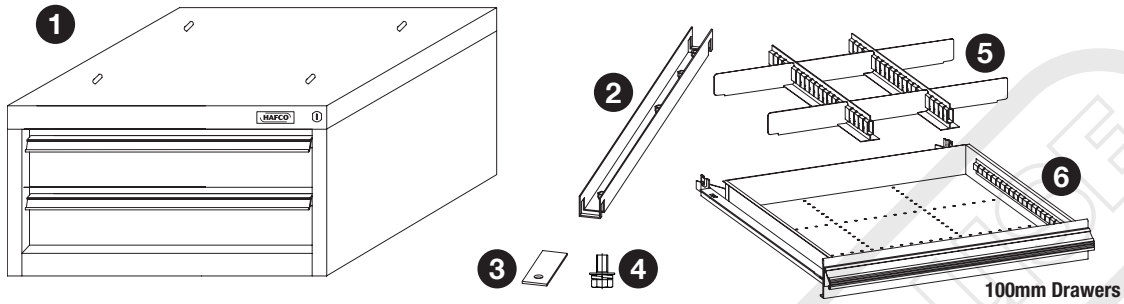

### HC-3

Part No.	Description	Qty
1	Cabinet	1
2	Mounting Brackets	2
3	Fixing Tab	2
4	Screw - for boom	6
5	100mm Divider Set	2
6	100mm Drawer	2
7	150mm Divider Set	1
8	150mm Drawer	1

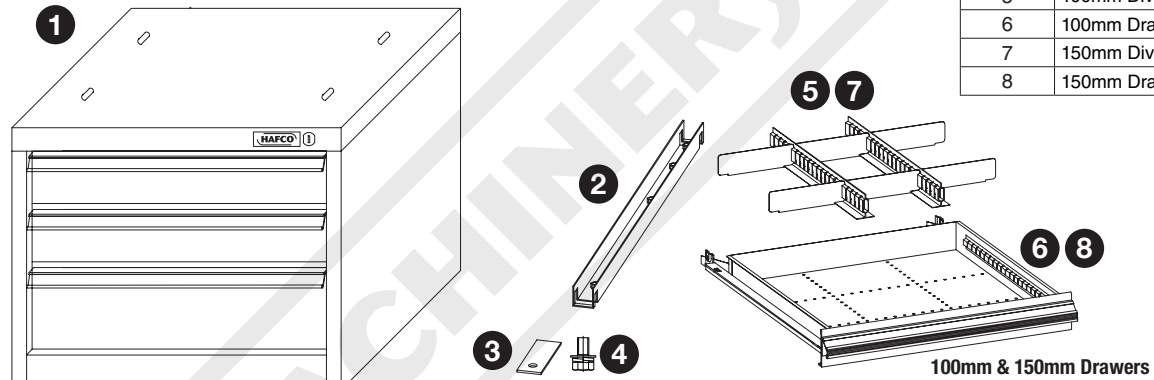

### HC-2W

Part No.	Description	Qty
1	Cabinet	1
2	Mounting Brackets	3
3	Fixing Tab	3
4	Screw - for boom	9
5	100mm Drawer	2
6	100mm Divider Set	2

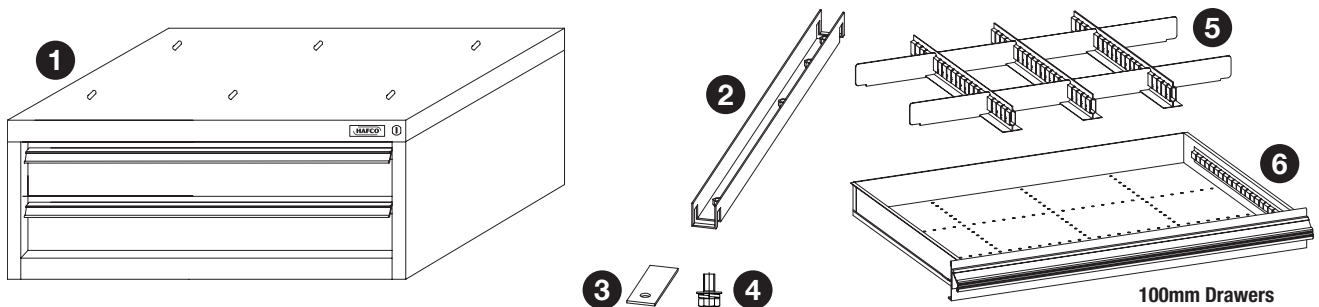

# MOUNTING UNDER BENCH - INSTRUCTIONS



Due to the weight of the table, it is highly recommended that you have a second person to assist during the build of the table, being made from steel it is heavy and help should be obtained to avoid any injuries.

## Suggestion of what you will need

Note - this assembly guide is merely a recommendation and should not be followed blindly, if you do not have the equipment or the experience necessary to complete this project you should consider seeking advice from a professional.

- 1/2" spanner or 1/2" socket wrench

**NOTE:** You may consider to use other methods and tools to help complete you project, the above list is just a suggestion. read through these instructions before starting the assembly process.

## Getting Started

Before starting the assembly ensure you have the correct tools & equipment to successfully assemble the table whilst making sure you are wearing the appropriate Safety PPE.



### Tooling cabinets suit Bench models: IWB-12, MWB-1275, IWB-40, IWB-2275



IWB-12



MWB-1275



IWB-40



IWB-2275



## Step 1

Remove the top drawer of tooling cabinet as shown.



## Step 2

Using a 1/2" spanner or 1/2" socket wrench assemble the 3 x mounting brackets. Then bolt on the 3 x clamps as shown below. Note: Leave clamp bolts loose for now.

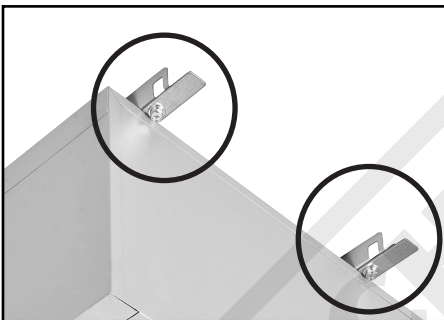

### NOTE:

Example shows HC-2W with 3 x Mounting Brackets

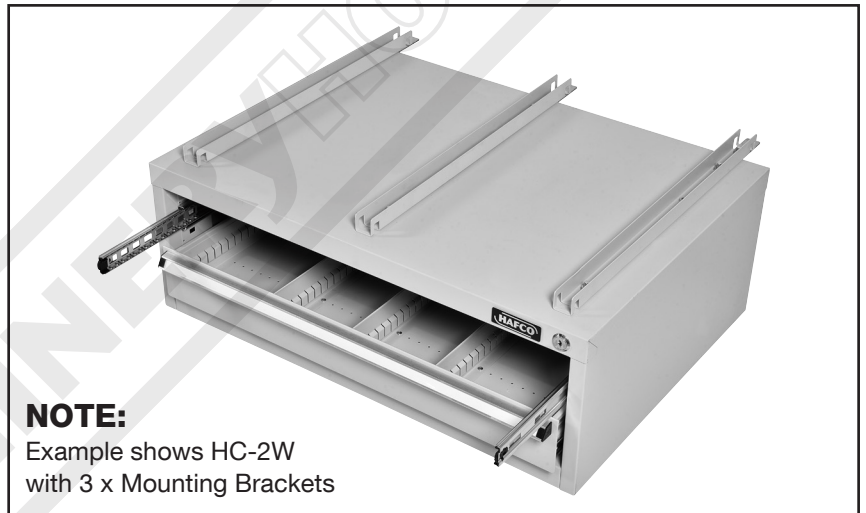

## Step 3

Flip tooling cabinet upside down as shown.

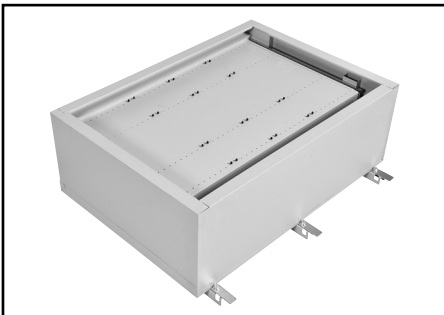

## Step 4

If work bench is already assembled, remove one leg frame and the rear leg cross support as shown.



## Step 5

Slide the tooling cabinet onto the work bench while keeping the rear clamps above the table frame as shown below.

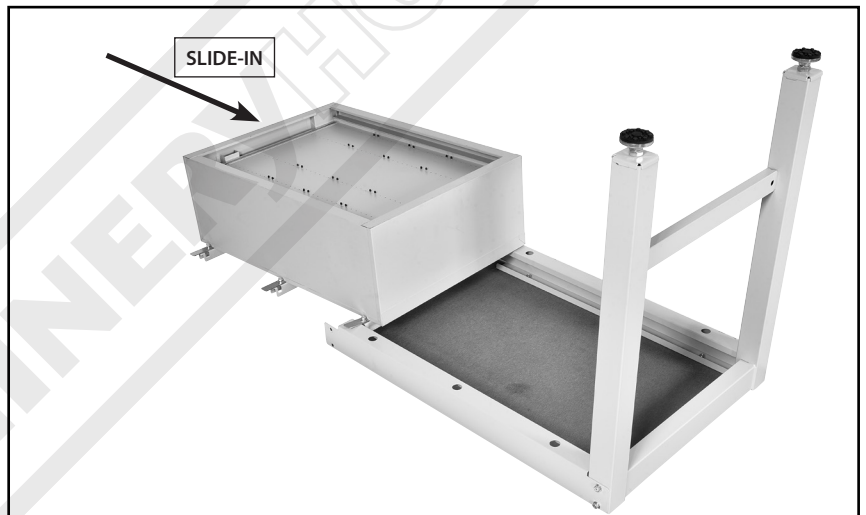

## Step 6

Proceed to slide the tooling cabinet unit onto the work bench as shown.

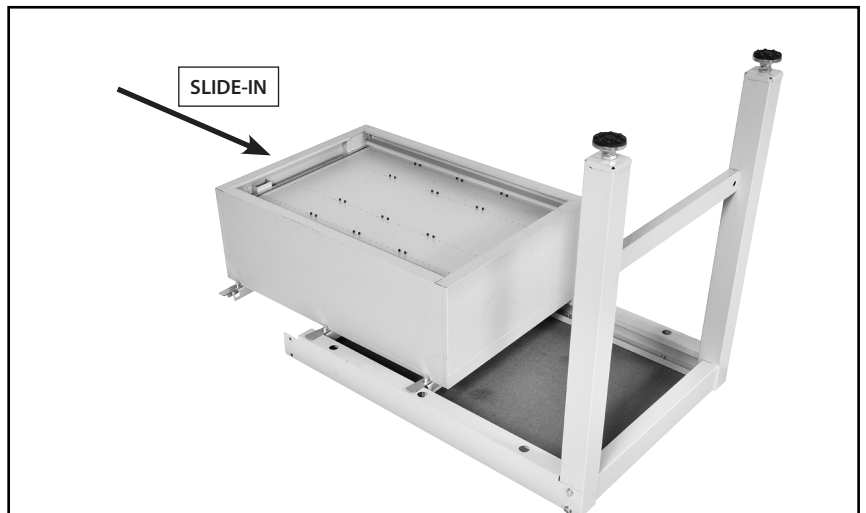
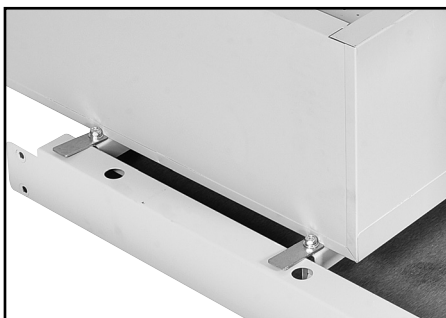

## Step 7

Slide the drawer unit to desired location or in the case of this model as shown all the way to the end until touches the legs.

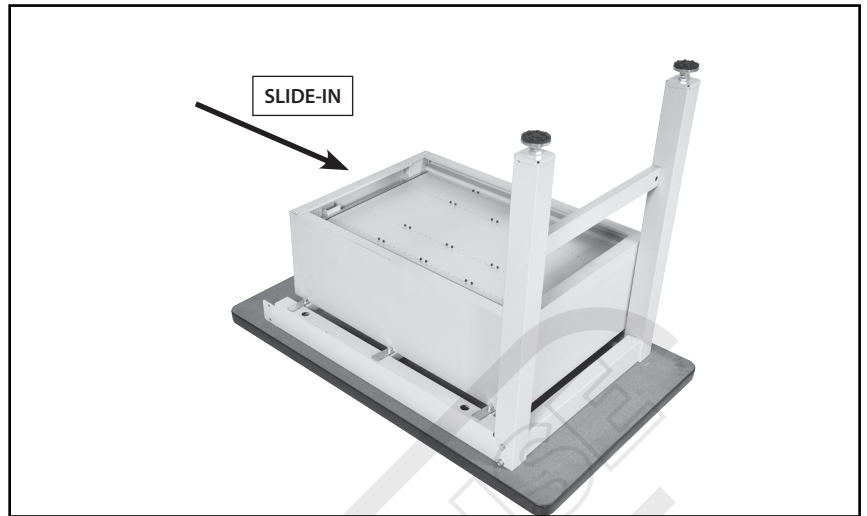

## Step 8

Re-assemble the work bench rear leg cross support as shown.

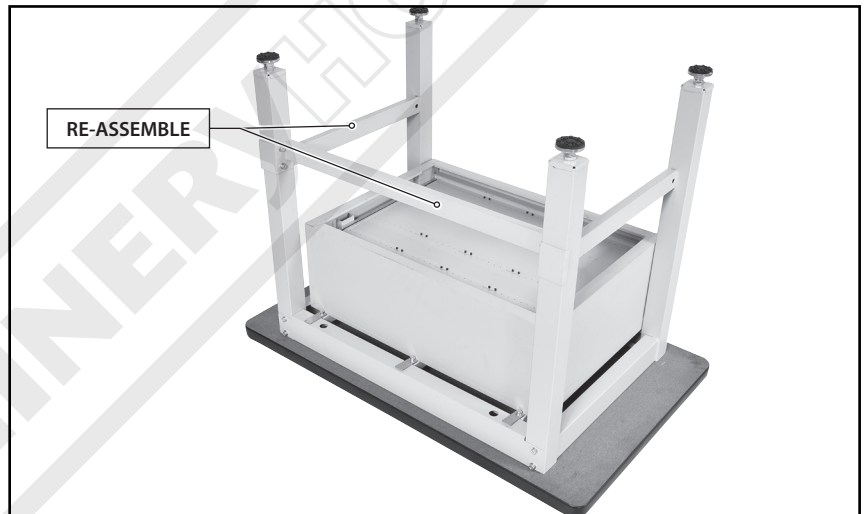

## Step 9

Using a 1/2" spanner, tighten all rear clamps as shown.

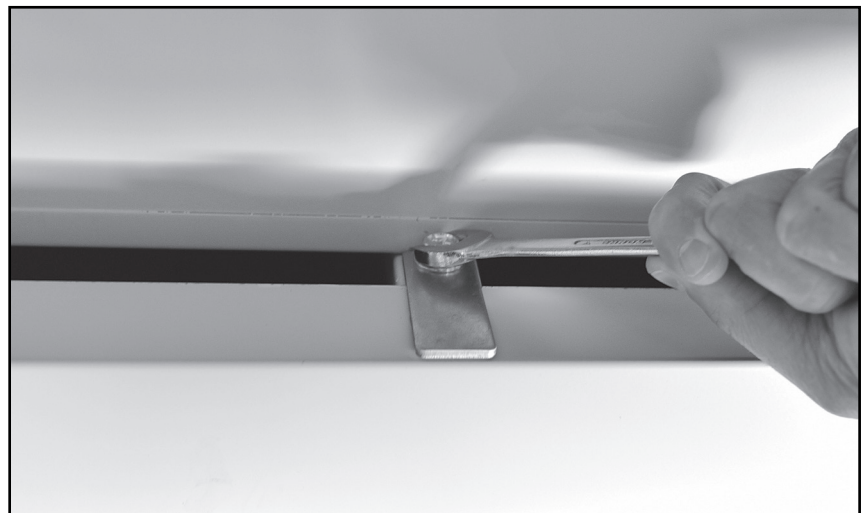

**Step 10**

Flip table to the upright position as shown.

**Step 11**

Install the top drawer of the tooling cabinet as shown.

The work bench with under bench tooling cabinet is now ready for use.







### ENVIRONMENT PROTECTION

Recycle unwanted materials instead of disposing of them as waste. All tools, accessories and packaging should be sorted, taken to a recycling centre and disposed of in a manner which is compatible with the environment. When the product becomes completely unserviceable and requires disposal, drain any fluids (if applicable) into approved containers and dispose of the product and fluids according to local regulations.

Imported by

**HARE & FORBES**  
**MACHINERYHOUSE**

Australian Distributor

**Hare & Forbes**  
**Machineryhouse**  
Sydney - Melbourne  
Adelaide - Brisbane - Perth

Ph: 1300 202 200  
[www.machineryhouse.com.au](http://www.machineryhouse.com.au)

**MACHINERYHOUSE**

New Zealand Distributor

**Machineryhouse**  
Auckland  
Christchurch

Ph: 0800 142 326  
[www.machineryhouse.co.nz](http://www.machineryhouse.co.nz)